

# UNINTERRUPTIBLE MILLISECOND SWITCHING DUAL AUTOMATIC TRANSFER SWITCH OPERATING INSTRUCTION

## Product Certificate

Model: XLQ4

Name: Dual power automatic transfer switch

The product is qualified after inspection and meets the standard GB/T 14048.11, and it is allowed to leave the factory.

Inspector:

Inspection date: see product packaging

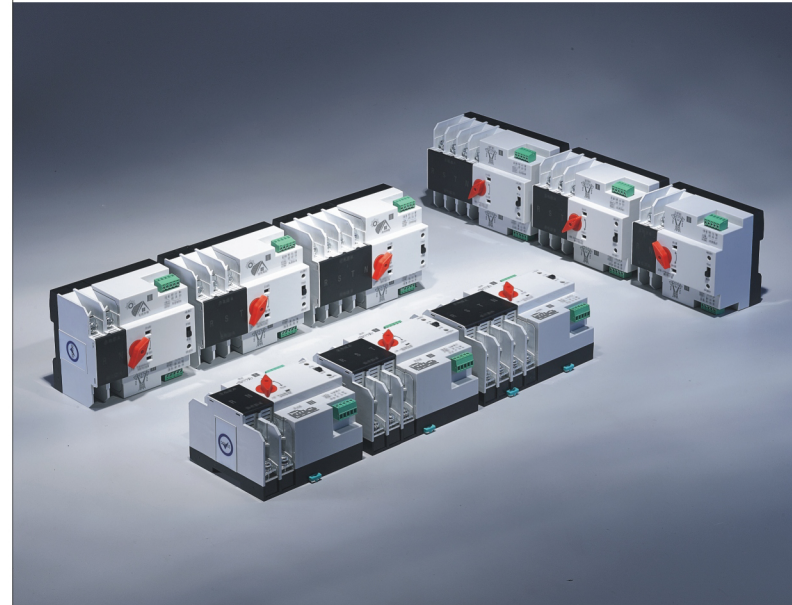

Please read the instructions carefully, when product acceptance and installation, and retain it for future reference.

# CONTENTS

1. General .....	3
2. Normal operation time and installation conditions .....	3
3. Model and meaning .....	4
4. Main technical parameters .....	4
5. 100 type wiring diagram .....	5
6. Overall and installation dimension of 100 .....	6
7. Installation and wiring .....	7
8. Maintenance, inspection and storage .....	7
9. Matters needing attention .....	8

# PREFACE

Dear user:

Thank you for using our products, we believe this product will give your work and life benefits and convenience, welcome your valuable suggestions and comments in the use course, we will continue to provide you with enthusiastic and attentive service. Or if you have any questions, please contact the manufacturer directly with our vendors.

This manual is for reference only. If the product or version upgrades to change without notice. Paid product to prevail. Thank you for your cooperation and support.

Control device: built in controller

Product structure: no power off, guide rail type, high current, small volume, two-stage type, simple structure, ATS integration

Features: fast switching speed, low failure rate, convenient maintenance and reliable performance

Wiring mode: front plate wiring

Conversion mode: power grid to power grid, power grid to generator, photovoltaic to urban power, automatic switching and self recovery

Product frame: 100

Product current: 10, 16, 20, 25, 32, 40, 50, 63, 80, 100A

Product classification: direct load type

Pole No.: 2, 3, 4

Standard: GB/T14048.11

A T S E: PC class

Switching time: 0.008s/8ms

### 1. General

The dual power automatic switch is a newly developed miniature household power switch, which is mainly used to test whether the main power supply or standby power supply is normal. When the normal power supply is abnormal, the standby power supply starts to work immediately, which ensures the continuity, reliability and safety of power supply. This product is specially designed for household rail installation and is specially used for PZ30 distribution box.

The dual power automatic switch is suitable for emergency power supply systems with 50 or 60Hz and rated 400V AC. ATS has the characteristics of solid structure, reliable conversion, convenient installation and maintenance and long service life. It is widely used in various occasions where power failure cannot be sustained, and can be operated by electricity or manually. ATS is composed of TSE and controller.

According to GB/T14048.11, Part 6-1: multifunctional equipment and switchgear is formulated. It can be seen that ATS is the most qualified low-voltage switchgear and control device.

### 2. Normal operation time and installation conditions

#### 2.1 Ambient air temperature

The maximum temperature shall not exceed 40°C, the minimum temperature shall not be lower than -5°C, and the average temperature within 24 hours shall not be higher than 35°C.

#### 2.2 Altitude

The altitude of the installation site should not be higher than 2000m.

#### 2.3 Atmospheric conditions

When the maximum temperature reaches 40°C, the relative humidity of the installation site should not exceed 50%; when the temperature is the minimum temperature -5°C, the relative humidity is higher, for example, the temperature is 25°C, and the relative humidity is 90%. Due to the temperature change, special measures should be taken to deal with the occasional condensation on the surface of the product.

#### 2.4 Pollution grade

The pollution grade of ATS conforms to grade 3 specified in GB/T14048.11.

#### 2.5 Installation category

The installation type of ATS conforms to the category specified in GB/T14048.11.

#### 2.6 Installation conditions

ATS can be installed vertically in control cabinet or distribution cabinet. Make sure the installation distance meets the requirements in Figure 1.

### 3. Model and meaning

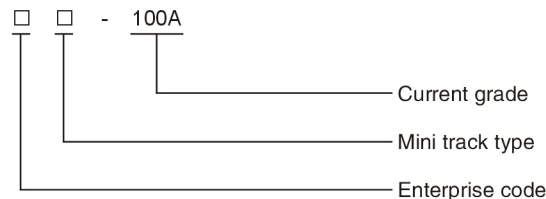

### 4. Main technical parameters

Specification	100A		
Rated current Ie(A)	16, 20, 25	32, 40, 50, 63	80, 100
Insulation voltage Ui	AC690V, 50Hz		
Rated voltage Ue	AC400V, 50Hz		
Classification	PC class: can be manufactured and withstood without short circuit current		
Utilization category	AC-33iB		AC-31B
Pole No.	2P	3P	4P
Weight(kg)	1.7	2.1	2.6
Electrical	Life: 2000 times; Manual operation: 5000 times		
Rated short circuit current Iq	50kA		
Short circuit protection device (fuse)	RT16-00-63A		
Rated impulse withstand voltage	8kV		
Control circuit	Rated control voltage Us: AC220V/50Hz Normal working conditions: 85-110%Us		
Auxiliary circuit	2 relays, each with two sets of contact converter contact capacity: AC220V/50Hz Ie=5y		
Conversion time of contactor	<50ms		
Operation conversion time	<50ms		
Return conversion time	<50ms		
Power off time	<50ms		

## 5. 100 type wiring diagram

### Internal wiring diagram

Fig.1

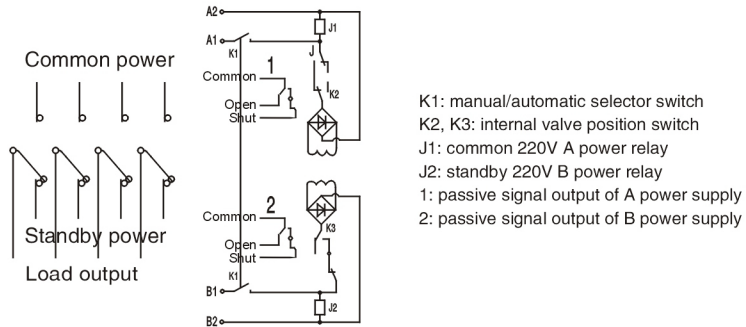

### Controller wiring diagram

Fig.2

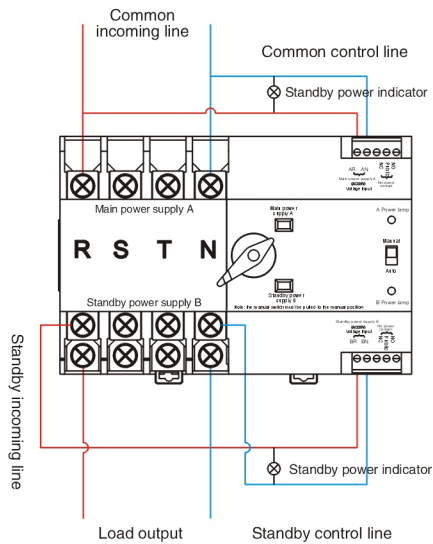

### 100/2P wiring diagram

Fig.3

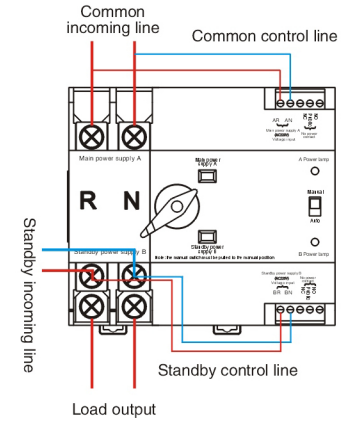

### 100/3P wiring diagram

Fig.4

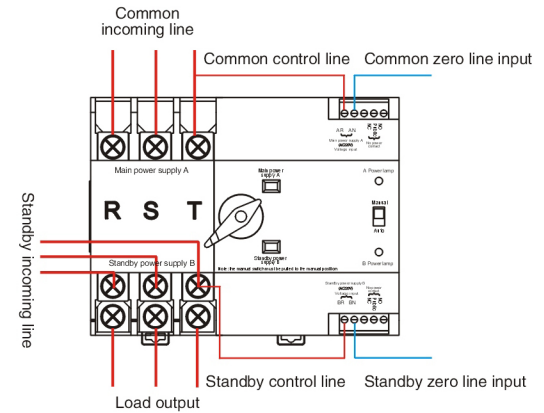

# DUAL POWER AUTOMATIC TRANSFER SWITCH

## ■ 100/4P wiring diagram

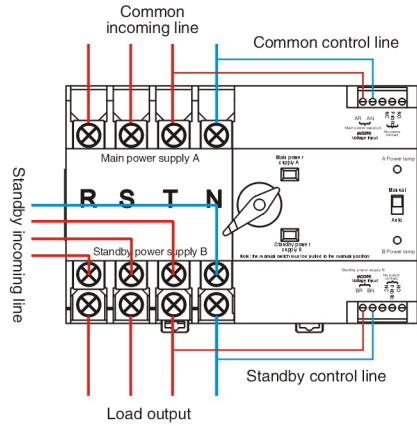

Fig.5

## ■ Timing switching connection mode

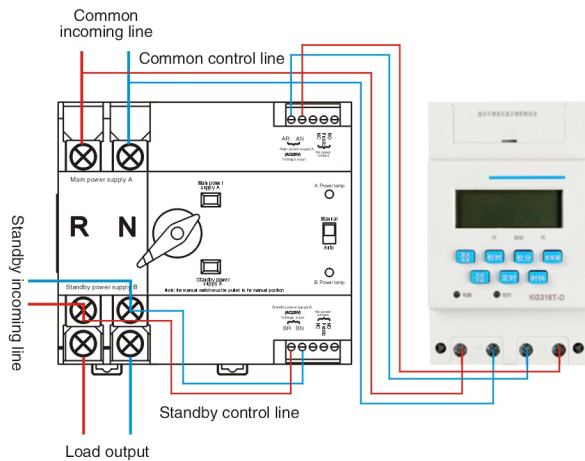

Fig.6

# DUAL POWER AUTOMATIC TRANSFER SWITCH

## ■ Special connection mode of photovoltaic inverter

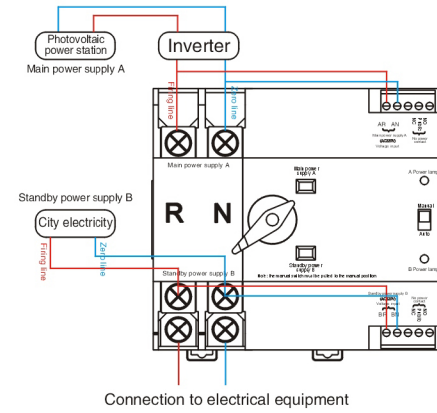

Fig.7

## 6. Overall and installation dimension of 100

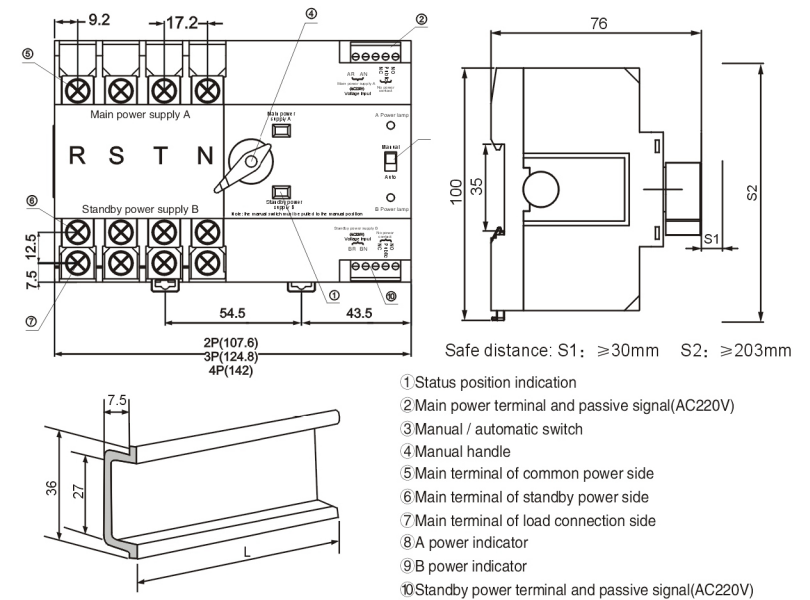

Fig.8

## 7. Installation and wiring

- 7.1 Ensure that professionals read this manual before installation and wiring.
- 7.2 Please check the integrity of ATS before installation, then open and close ATS with the operating handle, check the flexibility of transmission device and detect the load generation and disconnection conditions of common and standby power supplies at each stage.
- 7.3 See the figure for the correct installation steps. The trademark is in front of the product. If the installation cannot be carried out according to the correct procedures due to wiring and other reasons, please contact us. The safe distances S1, S2 should not be lower than the labels in Fig. 8. (See figure below for details)
- 7.4 Detection control voltage: 50Hz, AC220V. The coil in the control circuit cannot be too long. The cross-sectional area of copper wire should not be greater than 2.0mm<sup>2</sup>.
- 7.5 According to the installation requirements of power distribution system, please provide appropriate circuit breakers to ensure the safety of staff and equipment.

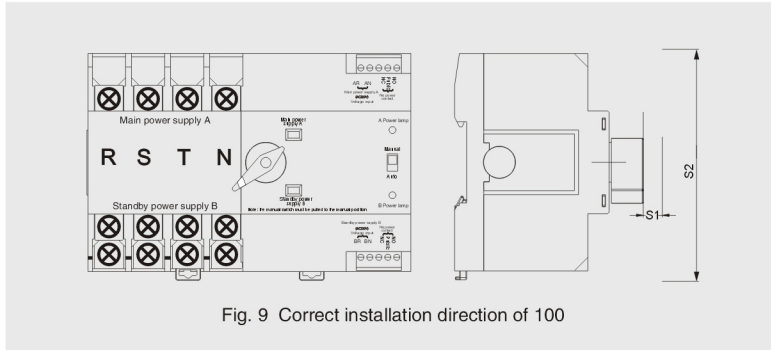

Fig. 9 Correct installation direction of 100

## 8. Maintenance, inspection and storage

- 8.1 Maintenance and inspection shall be operated by professionals and all power supplies shall be cut off in advance.
- 8.2 In order to ensure the good performance of ATS, the first maintenance and inspection shall be carried out within 6 months after use, and shall be maintained and inspected at least once a year. In harsh installation conditions, the frequency of maintenance and inspection should be increased.

### 8.3 Maintenance and Inspection Items

- a. Please remove dust and dirt in case of failure.
  - b. Please check whether the contact parts of the electrical contacts are deformed and damaged, and remove burnt metal particles attached to and around the surface.
  - c. Rust, acidification and dust on the contact surface may lead to poor contact. Please operate manually many times and measure the contact resistance if necessary.
  - d. Due to long-term moisture and suspension, please dry ATS before use. After removing dust and dirt, use a 500V megohmmeter to measure the insulation resistance between normal supply, alternating power supply, load side bar, including live parts and metal plate. And the insulation resistance should not be less than 10M.
- 8.4 ATS shall be stored in an environment equivalent to the normal working environment, with dust-proof, moisture-proof and collision-proof measures.

## 9. Matters needing attention

### 9.1 Manual/automatic operation

ATS can guarantee the performance of power generation and power failure during circuit operation, but for manual operation, ATS cannot guarantee the above performance due to the difference of power generation and power failure speed or operator. During manual power generation and power failure, excessive silver alloy loss may occur. Therefore, when all power supplies are cut off to check and maintain the operating system and contacts, it is only necessary to pull the selector switch to the manual position. Under normal circumstances, please pull the selector switch to the automatic position. When operating manually, pull the selector switch to the manual position. After the manual operation is completed, pull the selector switch from the manual position to the automatic position.

### 9.2 Control circuit

ATS instantly becomes active. After the conversion is completed, the coil in the control circuit will be disconnected by the internal converter. Under the rated voltage of 80%–110%, the coil can operate normally. Low voltage will cause coil heating and even spontaneous combustion.