



USER MANUAL

LiFePO4 Battery System for Households



LiFePO4 Battery System

Contents

1.ABOUT THIS MANUAL	1
1.1 Purpose.....	1
1.2 Scope.....	1
1.3 Safety Instructions.....	1
1.4 Can be connected in parallel.....	1
1.5 Safety rules.....	2
1.6 Safety information.....	2
1.7 Installation.....	2
2.SYMBOLS	3
3.TRANSPORTATION	3
3.1 Regulations for the transport of battery modules.....	3
3.2 Permissible and Impermissible Storage Positions of a Packaged.....	4
4. STORAGE	4
5.INTRODUCTION	5
5.1 Features	5
5.2 Product Overview	5
5.3 Switch On/Off.....	6
5.4 Description for Communication port.....	6
5.5 Specifications.....	7
6.INSTALLATION	8
6.1 Tools.....	8
6.2 Items in the package.....	8
7. INSTALLATION PROCEDURE	9
7.1 Floorinstallation with base.....	9
7.2 Setup Script.....	10
7.3 Install Environmentf.....	10
7.4 Terminal Connection.....	10
8. OPERATION	11
8.1 Battery system switch operation.....	11
8.2 Connection for Parallel Mode.....	11
8.3 Parallel DIPSwitch.....	12
8.4 Commissioning.....	12
8.5 ON/OFF or SOC Led (Mode or SOC).....	13
8.6 DIP switch SW1-SW4 Description.....	13

9. EMERGENCY SITUATIONS	14
9.1 Fire.....	14
9.2 Leaking Batteries.....	14
9.3 Wet Batteries.....	14
9.4 Damaged Batteries.....	14
9.5 Warranty.....	14
10.TROUBLESHOOTING AND MAINTENANCE	15
10.1Maintenance.....	15
10.2Troubleshooting.....	15

1 ABOUT THIS MANUAL

1.1 Purpose

This manual describes the introduction, installation, operation and emergency situations of the battery bank. Please read this manual carefully before installations and operations. Keep this manual for future reference.

1.2 Scope

This manual provides safety and installation guidelines as well as information on tools and wiring.

1.3 Safety Instructions



WARNING: This chapter contains important safety and operating instructions. Read and keep this manual for future reference.

1. Before using the unit, read all instructions and cautionary markings on the unit, the batteries and all appropriate sections of this manual.
2. CAUTION --- To reduce risk of injury, damage, even burst. please use it following using manual. In case of causing personal
3. Do not disassemble the battery. Take it to a qualified service center when service or repair is required. Incorrect re-assembly may result in a risk of fire.
4. To reduce risk of electric shock, disconnect all wirings before attempting any maintenance or cleaning. Turning off the unit will not reduce this risk.
5. CAUTION – Only qualified personnel can install this device with inverter.
6. For optimum operation of this battery, please follow required spec to select appropriate cable size.
7. Be very cautious when working with metal tools on or around batteries. A potential risk exists to drop a tool to spark or short circuit batteries or other electrical parts and could cause an explosion or fire.
8. Please strictly follow installation procedure.
9. GROUNDING INSTRUCTIONS - This System should be connected to a permanent grounded wiring system. Be sure to comply with local requirements.
10. NEVER cause AC output and DC input short circuited. Do not connect to the mains when DC input short circuits.
11. Warning!! Only qualified service persons are able to service this device.
12. Battery should be installed indoor and kept away from water, high temperature mechanical force and flames.
13. Do not install the battery in any environment of temperature below 0°C or over 55°C, and humidity over 80%.
14. Do not put any heavy objects on the battery.

1.4 Can be connected in parallel

1. The batteries can be connected in parallel. Series connection is not allowed. Use in upright position only.

2. The batteries are not allowed to connected with PWM controller for charging.

Special Attention: Due to the built-in protection board of the lithium battery pack is with over-discharge protection function, it is strongly recommended to stop using the load when the battery pack is over-discharged. The battery pack cannot be repeatedly activated for discharge. Or the battery may be failed to be activated by the AC or PV activation cable (It requires a special charging activation method), so cannot be charged. Therefore, when the battery pack is low power, please charge the battery as soon as possible when main power or solar energy is available.

1.5 Safety rules

To avoid property damage and personal injury, the following rules shall be followed when working on the hazardous live parts of the battery energy storage system:

- It is available for use.
- Ensure that it will not restart.
- Make sure there is no voltage.
- Grounding protection and short circuit protection.
- Cover or shield adjacent live parts.

1.6 Safety information

Part damage or short circuit may cause electric shock and death. A short circuit can be caused by connecting battery terminals, resulting in current flow. This type of short circuit shall be avoided under any circumstances. For this reason, follow these instructions:

- Use insulated tools and gloves.
- Do not place any tools or metal parts on the battery module or high-voltage control box.
- When operating the battery, be sure to remove watches, rings, and other metal objects.
- Do not install or operate this system in explosive or high-humidity areas.
- When working on the energy storage system, first turn off the charging controller, then the battery, and ensure that they are not turned on again.

Improper use of the battery energy storage system can lead to death. The use of the battery energy storage system beyond its intended use is not allowed, because it may cause great danger.

Improper handling of the battery energy storage system can cause life-threatening risks, serious injury or even death.



Warning! improper use can cause damage to the battery cell.

- Do not expose the battery module to rain or soak it in liquid.
- Do not expose the battery module to a corrosive environment (such as ammonia and salt).

1.7 Installation

- After unpacking, please check the product for damages and missing parts.
- Make sure that the inverter and battery is completely turned off before commencing installation.
- Do not interchange the positive and negative terminals of the battery.
- Ensure that there is no short circuit of the terminals or with any external device.
- Do not exceed the battery voltage rating of the inverter.
- Do not connect the battery to any incompatible inverter.
- Do not connect different battery types together.
- Please ensure that all the batteries are grounded properly.
- Do not open the battery to repair or disassemble. Only FelicityESS is allowed to carry out any such repairs.
- In case of fire, use only dry powder fire extinguisher. Liquid extinguishers should not be used.
- Install the battery away from children or pets.
- Do not use battery in high static environment where the protection device might be damaged.
- Do not install with other batteries or cells.

2. SYMBOLS

 Danger! Serious physical injury or even death may occur if not follow the relative requirements.	 Install the product out of reach of children
 Caution, risk of electric shock.	 Do not place nor install near flammable or explosive materials
 In case of electrolyte leakage, keep leaked electrolyte away from eyes or skin.	 Disconnect the equipment before carrying out maintenance or repair
 Do not connect the Pack's positive(+) and negative(-)terminal reversely.	 Societe Generale de Surveillance S.A.
 Observe precautions for handling electrostatic discharge sensitive devices.	 Instruction manual: Read the instruction manual before starting installation and operation.
 Caution, risk of electric shock, energy storage timed discharge	 CE mark: The inverter complies with the CE directive.
 Recyclable.	NOTE Note: The procedures taken for ensuring proper operation.
 Do not use the Pack beyond specified conditions	 Earth terminal The inverter must be reliably grounded.
 Take care! This Pack is heavy enough to cause serious injury.	 EU WEEE mark: Product should not be disposed as household waste.

3. TRANSPORTATION

3.1 Regulations for the transport of battery modules

It is necessary to comply with the relevant regulations and provisions on roads for shipping lithium-ion products in the corresponding countries.

 • Smoking is prohibited in the vehicle during transportation or in the vicinity during loading and unloading

 • The dangerous goods transport vehicles shall meet relevant regulations concerning road transportation and shall be equipped with two tested CO2 fire extinguishers.

 • The battery energy storage system can be damaged, if not properly transported. The battery module can only be transported vertically. Note that these parts may be top-heavy. Failure to follow this instruction may result in damage to the part.



• If possible, do not remove the transport packaging before arrival at the installation site. Before removing the transport protector, check if the transport packaging is damaged.



• Improper transport of battery modules may cause injury. The single battery module weighs 64.5kg. It could cause injury if it falls or slips. Use only suitable transport and lifting equipment to ensure safe transport.



• Wear safety shoes to avoid the danger of injury. When transporting the battery module, their parts may be crushed due to their heavy weight. Therefore, all persons involved in transportation must wear safety shoes with toe caps. Please observe the safety regulations for transportation at the end customer's site, especially during loading and unloading.



• During transportation and installation of unpacked battery storage cabinets, the risk of injury increases, especially on sharp metal panels. Therefore, all personnel involved in transportation and installation must wear protective gloves.



• Improper vehicle transportation can cause injury. Improper transportation or improper transportation locks may cause the load to slip or overturn, resulting in injury.

3.2 Permissible and Impermissible Storage Positions of a Packaged

The battery module can only be transported in an upright position.



4. STORAGE

- Do not expose battery to open flame.
- Do not place the product under direct sunlight.
- Do not place the product near flammable materials. It may lead to fire or explosion in case of accident.
- Store in a cool and dry place with ample ventilation.
- Store the product on a flat surface.
- Store the product out of reach of children and animals.
- Do not damage the unit by dropping, deforming, impacting, cutting or penetrating with a sharp object. It may cause leakage of electrolyte or fire.
- Do not touch any liquid spilled from the product. There is a risk of electric shock or damage to skin.
- Always handle the battery wearing the insulated gloves.
- Do not step on the product or place any foreign objects on it. This can result in damage
- Do not charge or discharge damaged battery.

5. INTRODUCTION

5.1 Features

- LiFePO4: Higher safe performance and longer cycle life.
- Multiple Protection: Built-in smart BMS and Breaker.
- Flexible Installation: Wall-Mounted or Floor-Mounted.
- Wide Compatibility: Compatible with leading inverter brands.
- High Scalability: Capacity up to 61.44kWh.

5.2 Product Overview



Code	Name
A	Battery Negative-
B	Battery Positive+
C	Breather Valve
D	GND
E	Link-1
F	Link-0
G	RS485 Communication
H	PCS Communication
I	SW
J	Handle
K	Power Breaker
L	LED Display
M	Power Switch

5.3 Switch On / Off

Switch on: close the breaker to the ON block, press and hold Power switch for 1 seconds, the battery will perform self-test before output. The LED will show SOC.
 Switch off: close the breaker to the OFF block, the battery will shut down directly.

5.4 Description for Communication port

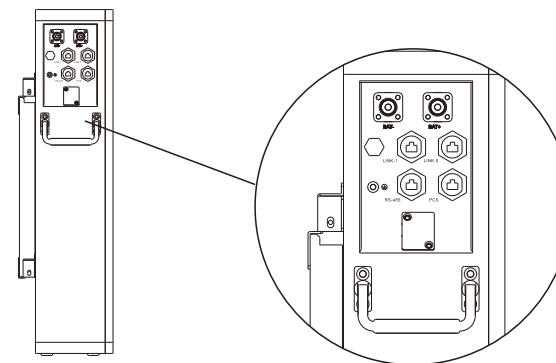

LINK-0/LINK-1
(Parallel communication interface)

Pin	Function Definitions	Function Declaration
1	GND	Power/signal ground
2	NC	
3	NC	
4	NC	
5	485B	RS485-B
6	485A	RS485-A
7	CANL	CANL
8	CANH	CANH

RS-485

Pin	Function Definitions	Function Declaration
1	GND	Power/signal ground
2	12V	
3	NC	
4	NC	
5	485B	RS485-B
6	485A	RS485-A
7	NC	
8	NC	

5.5 Specifications

LUX-E-48100LG04 photovoltaic energy storage system is a 48V energy storage system based on lithium-ion ferrous phosphate battery. It is equipped with a customized battery management system(BMS),Which is designed for energy storage applications of household photovoltaic power generation users.in the daytime,the surplus power of photovoltaic generation can be stored in the battery.At night or when necessary,the stored energy can be provided to the electrical equipment,it can improve the use efficiency of photovoltaic power generation,peak-load shifting,and provide emergency standby power.

Model	LUX-E-48100LG04
Battery Type	LiFePO4
Nominal Energy	5.12kWh
Nominal Capacity	100Ah
Nominal Voltage	51.2V
Operating Voltage	44.8~57.6V
Recommend Charge/Discharge Current	50A
Max.continuous charge/Discharge current[1]	60A
Peak Charge/Discharge Current(15s)	100A
Scalability	Max.12 pcs in Parallel(61.44kWh)
Depth of Discharge(DOD)	≥ 95%
Display type	LED
IP Rating of Enclosure	IP65
Working Temperature Range	Charge: 0°C~55°C
	Discharge:-20°C~55°C
Storage Temperature Range	0°C~+35°C
Humidity	5%~95%
Altitude	≤ 2000m
Communication	RS485 / CAN
Cycle Life[2]	≥ 6000 Cycles
Installation	Wall-Mounted / Floor-Mounted
Protection	Built-in smart BMS, Breaker
Warranty Period[3]	10 Years
Product Weight Approximate	48.5 kg
Package Weight Approximate	64.5 kg
Product Dimension	665x440x175 mm
Package Dimension	760x540x345 mm
[1] Max.continuous charge/Discharge current is affected by temperature and SOC.	
[2] Test conditions: 0.2C Charging/Discharging @25°C, 80% DOD.	
[3] Conditions apply, refer to FelicityESS Warranty policy.	

6.INSTALLATION

6.1 Tools



Screw Driver



Crimping Modular



Safety Shoes



Multimeter



Safety Gloves



Safety Goggles



Plier





Ribbon

6.2 Items in the package

Please check if following items are including with the package:

NO.	DESCRIPTION	QUANTITY (PCS)	PICTURE
1	Wall Mount: used for securing the product.	1	
2	User manual	1	
3	Warranty card	1	
4	Terminal: When the wiring length is insufficient for actual use, customers need to prepare the corresponding power cables and crimp this terminal for use.	2	
5	Screw: used for installing the product's handle.	8	
6	Plastic Expansion Screw: used for securing the product's wall mount.	5	
7	Stainless Steel Handle: used for transporting the product.	2	
8	Communication Cable 1: used for CAN/RS485 communication with inverters from other brands.	1	
9	Communication Cable 2: used for RS485 communication with Felicity inverters.	1	

10	Communication Cable 3: used for parallel communication with battery packs.	1	
11	Power Cable: 0.9 meters, 25mm ² , allows for charging and discharging up to 125A, used for connecting to external PCS.	2	
12	Signal Terminal: used for creating custom communication cables.	2	

7. INSTALLATION PROCEDURE

7.1 Floor installation with base

Installation Location Requirements

Consider the following points before selecting where to install:

- Do not mount the battery on flammable construction materials.
- The ambient temperature should be between 0°C and 45°C to ensure optimal operation.
- The recommended installation position is to be adhered to the wall vertically.
- Be sure to keep other objects and surfaces as shown in the right diagram to guarantee sufficient heat dissipation and to have enough space for removing wires.

LUX-E-48100LG04	
A	100
B	240
C	190.5
D	301
E	368
F	301
G	173.5
H	150
I	140

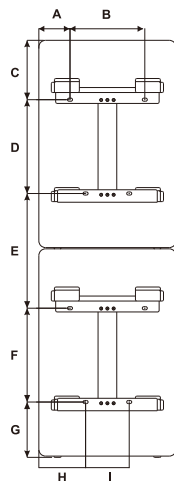

7.2 Setup Script

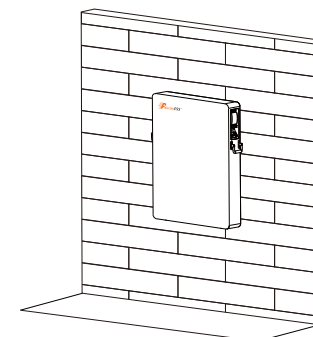
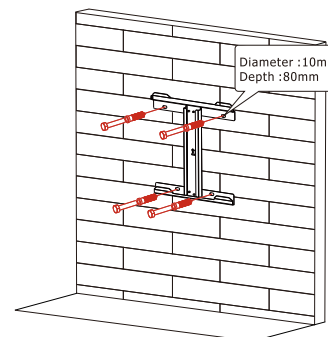

7.3 Install Environment

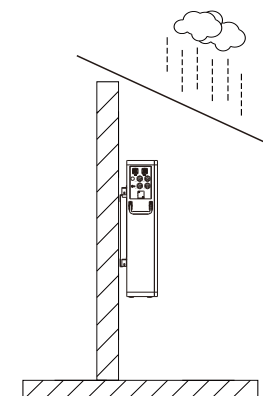
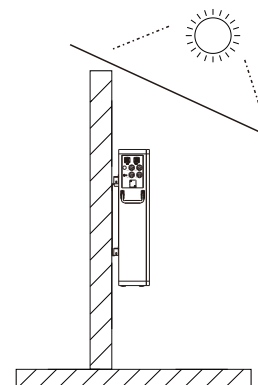

Note: Build sun & rain shade to avoid direct exposure to sunlight and rain.

7.4 Terminal Connection

Power terminal

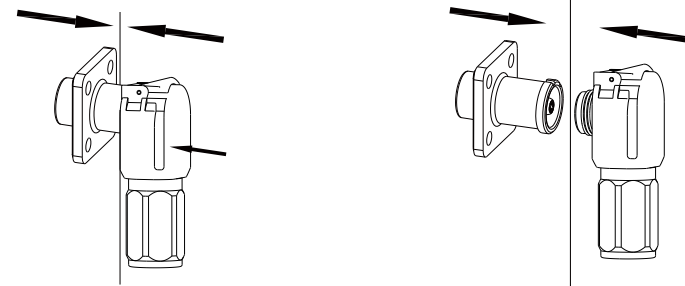

Note: Press the position indicated in the figure above before disconnecting the power terminal.

Communication terminal

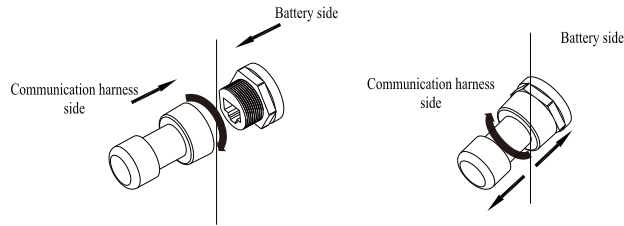

8. OPERATION

8.1 Battery system switch operation

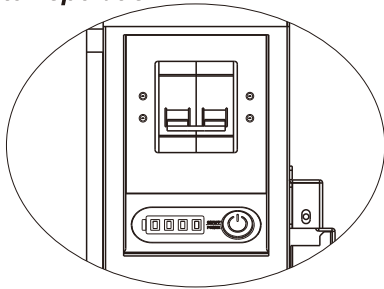

Power on battery system:

Turn the breaker to the "ON" state, press the POWER button 1 seconds, wait for the battery system LED light to light up, indicating that the boot is complete.

Power off battery system:

Turn the breaker to the "OFF" state, turn off the entire battery system.

8.2 Connection for Parallel Mode

The LUX-E-48100LG04 series battery support to be connected in parallel for expansion. If you need one more battery bank to work in parallel mode, connect the battery as shown in Figure 1.

* When multiple batteries are connected in parallel, we recommend using bus boxes (BTCB0606/BTCB0303) or copper bars for parallel connection

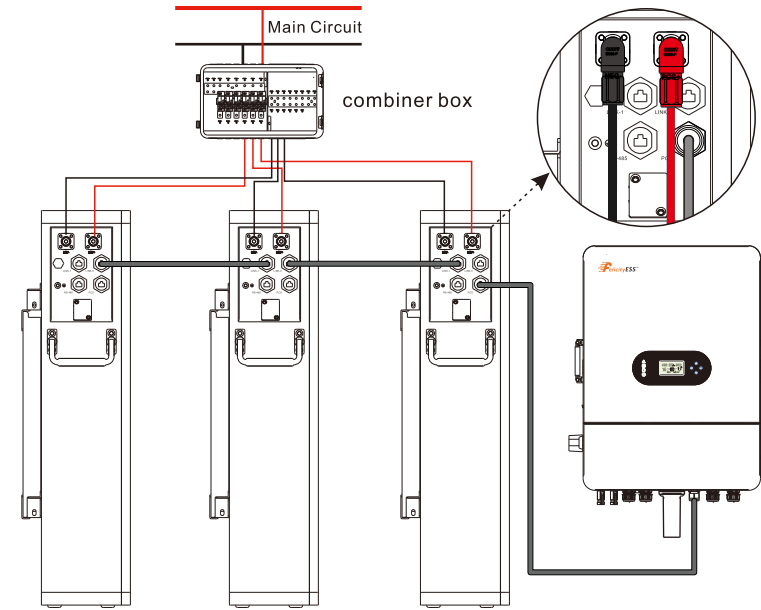

8.3 Parallel DIP Switch

Adjust each battery pack dialer from left to right according to the diagram below (from top to bottom)

No.of BAT	1	2	3	4	5	6	7	8	9	10	11	12
1PCS	1,5 ON											
2PCS	1,5 ON	2,5 ON										
3PCS	1,5 ON	2 ON	1,2,5ON									
4PCS	1,5 ON	2 ON	1,2 ON	3,5ON								
5PCS	1,5 ON	2 ON	1,2 ON	3 ON	1,3,5ON							
6PCS	1,5 ON	2 ON	1,2 ON	3 ON	1,3 ON	2,3,5ON						
7PCS	1,5 ON	2 ON	1,2 ON	3 ON	1,3 ON	2,3 ON	1,2,3,5ON					
8PCS	1,5 ON	2 ON	1,2 ON	3 ON	1,3 ON	2,3 ON	1,2,3 ON	4,5ON				
9PCS	1,5 ON	2 ON	1,2 ON	3 ON	1,3 ON	2,3 ON	1,2,3 ON	4 ON	1,4,5ON			
10PCS	1,5 ON	2 ON	1,2 ON	3 ON	1,3 ON	2,3 ON	1,2,3 ON	4 ON	1,4 ON	2,4,5ON		
11PCS	1,5 ON	2 ON	1,2 ON	3 ON	1,3 ON	2,3 ON	1,2,3 ON	4 ON	1,4 ON	2,4 ON	1,2,4,5ON	
12PCS	1,5 ON	2 ON	1,2 ON	3 ON	1,3 ON	2,3 ON	1,2,3 ON	4 ON	1,4 ON	2,4 ON	1,2,4,ON	3,4,5ON

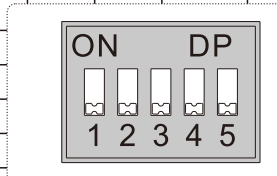

8.4 Commissioning

There are four LED indicators on the front of the battery packs to show its operating status.

SOC LED indication

100%	75%	50%	25%	Flashing SOC <10%

8.5 ON / OFF or SOC Led (Mode or SOC)

BATTERY MODE	ON/OFF		SOC				REMARK
	GREEN LED	RED LED	LED1	LED2	LED3	LED4	
POWER OFF	OFF	OFF	OFF	OFF	OFF	OFF	
POWER ON	OFF	ON	ON	ON	ON	ON	
STANDBY	OFF	OFF	SOC				SOC <10%(DEFAULT): LED1 FLASH
NORMAL	ON	OFF	RUNNING/SOC				SOC <10%(DEFAULT): LED1 FLASH
DISCHARGE	ON	OFF	SOC				SOC <10%(DEFAULT): LED1 FLASH
CHARGE	FLASH	OFF	RUNNING				
LOW POWER	FLASH	OFF	OFF				
FAULT	OFF	ON	ON	OFF	OFF	OFF	BATTERY VOLTAGE HIGH
			OFF	ON	OFF	OFF	BATTERY VOLTAGE LOW
			ON	ON	OFF	OFF	CELL VOLTAGE HIGH
			OFF	OFF	ON	OFF	CELL VOLTAGE LOW
			ON	OFF	ON	OFF	CHARGING CURRENT HIGH
			OFF	ON	ON	OFF	DISCHARGING CURRENT HIGH
			ON	ON	ON	OFF	BMS TEMPERATURE HIGH
			OFF	OFF	OFF	ON	BMS TEMPERATURE LOW
			ON	OFF	OFF	ON	CELL TEMPERATURE HIGH
			OFF	ON	OFF	ON	CELL TEMPERATURE LOW
ON	ON	OFF	ON	CURRENT SENSOR ABNOMAL			

8.6 DIP switch SW1-SW4 Description

DIP switch SW1-SW4 Description ①					DIP switch SW5 Description②	
Sw1	SW2	SW3	SW4	Remarks	SW5	Remarks
0	0	0	0	means ID=0,communication address is0x00/0x10③	1 0	means connect 120Ω resistor means disconnect 120Ω resistor
1	0	0	0	means ID=1,communication address is0x01④		
0	1	0	0	means ID=2,communication address is0x02		
1	1	0	0	means ID=3,communication address is0x03		
0	0	1	0	means ID=4,communication address is0x04		
1	0	1	0	means ID=5,communication address is0x05		
0	1	1	0	means ID=6,communication address is0x06		
1	1	1	0	means ID=7,communication address is0x07		
0	0	0	1	means ID=8,communication address is0x08		
1	0	0	1	means ID=9,communication address is0x09		
0	1	0	1	means ID=10,communication address is0x0A		
1	1	0	1	means ID=11,communication address is0x0B		
0	0	1	1	means ID=12,communication address is0x0C		
1	0	1	1	means ID=13,communication address is0x0D		
0	1	1	1	means ID=14,communication address is0x0E		
1	1	1	1	means ID=15,communication address is0x0F		
Remark①: 1 in SW1-SW5 indicates ON status, and 0 indicates OFF status.						
Remark②: When multiple battery packs communicate, the last battery pack SW5 needs to be in the ON status, otherwise the communication may have interference.						
Remark③: When the battery pack ID is set to 0, it means stand-alone operation, and it is not necessary to detect whether the parallel condition is satisfied ⑤						
Remark④: When the battery pack ID is set to 1-15, it means that the parallel operation is required, and it is necessary to detect whether the parallel condition is satisfied ⑤						
Remark⑤: The parallel condition is that the difference between the battery voltage of the local battery and all the battery pack voltages is <3V, otherwise wait until the condition is satisfied						

9. EMERGENCY SITUATIONS

FelicityESS cannot guarantee battery absolute safety.

9.1 Fire

In case of fires, make sure that the following equipment is available near the system.

- SCBA (self-contained breathing apparatus) and protective gear in compliance with the Directive on Personal Protective Equipment 89/686/EEC.
- NOVEC 1230, FM-200, or dioxide extinguisher

Batteries may explode when heated above 150°C. KEEP FAR AWAY from the battery if it catches fire.

9.2 Leaking Batteries

If the battery pack leaks electrolyte, avoid contact with the leaking liquid or gas. If one is exposed the leaked substance, immediately perform the cations described below.

- Inhalation: Evacuate the contaminated area, and seek medical attention.
- Contact with eyes: Rinse eyes with running water for 5 minutes, and seek medical attention.
- Contact with skin: Wash the affected area thoroughly with soap and water, and seek medical attention.
- Ingestion: Induce vomiting, and seek medical attention.

9.3 Wet Batteries

If the battery pack is wet or submerged in water, do not let people access it, and contact your supplier for help.

9.4 Damaged Batteries

Damaged batteries are not fit for use and are dangerous and must be handled with the utmost care. It may leak electrolyte or produce flammable gas. If the battery pack seems to be damaged, pack it in its original container, and then return it to your supplier.

9.5 Warranty

Products that are operated strictly in accordance with the user manual are covered by the warranty. Any violation of this manual may void the warranty.

Limitation of Liability

Any product damage or property loss caused by the following conditions, FelicityESS does not assume any direct or indirect liability.

- Product modified, design changed or parts replaced.
- Changed, or attempted repairs and erasing of series number or seals;
- System design and installation are not in compliance with standards and regulations;
- The product has been improperly stored in end user's premises;
- Transport damage (including painting scratch caused by movement inside packaging during shipping). A claim should be made directly to shipping or insurance company.

10.TROUBLESHOOTING AND MAINTENANCE

10.1 Maintenance

1.Regularly check whether the service environment of the battery meets the requirements, and the installation position should be far away from the heat source.

2.In case of one of the following situations, it needs to be charged in time:

- The battery is often under charged;

- The battery has been out of use or stored for more than 3 months.

3.Regularly check whether the battery and its supporting terminals, connecting cables and indicator lights are normal.

10.2 Troubleshooting

When the red / green LED on the panel is flashing or normally on, it does not mean that the Battery system is abnormal. it may be just an alarm or protection, Please check the 'LED fault message' in chapter 8 for the detailed faulty definition before any trouble-shooting steps. In general, the alarm indication is normal without manual intervention. When the alarm triggering state is removed, Battery system will automatically return to normal use.

- Problem determination based on the following points

- Whether the red light on the LUX-E-48100LG04 is on;
- Whether the battery can be output voltage or not.

- Preliminary determination steps

Battery system cannot work, when DC switch on and POWER on, the LED doesn't light up or flash, please consider contact the local distributor.