

EZ-HAC-T4A29-F2A

2MP Full-color HDCVI Eyeball Camera



System Overview

The EZ-IP Series is a great choice for consumers looking for high quality monitoring products at a reasonable price. Its low cost and high performance make it ideal for residential areas and SMB solutions. This series is equipped with a wide range of technologies, such as full-color and starlight, providing various solutions for different scenarios.

Functions

Full-color

With its advanced image processing algorithm and capability to absorb large quantities of light, the camera provides 24/7 color monitoring that collects clear and highly detailed information, significantly increasing the reliability of the human and vehicle images that are collected as evidence for intelligent analysis.

Broadcast-quality Audio

Audio signal transmission over coaxial cables is supported by the HDCVI camera. It adopts a unique audio processing and transmission technology that restores source audio and eliminates noise, ensuring the quality and reliability of the audio information that is collected. This becomes important for video surveillance applications that use audio information as a type of supplementary evidence.

Super Adapt

With its intelligent algorithm, the camera automatically adjusts its parameters to provide optimal performance and vivid images.

Advanced 3DNR

Dahua's advanced 3DNR technology reduces image noise with little to no impact on image sharpness, especially in poor lighting conditions. It detects the noise, and compares the sequential frames to effectively reduce the noise. It also makes efficient use of bandwidth, saving on storage space.

Smart Warm Light Illumination

In dark environments, the camera produces vivid images in rich color through its warm LED lights. With its smart light mode setting, it automatically adjusts its exposure time and light sensitivity to avoid the overexposure of objects in the center of the image.

- Max. 30 fps@1080p.
- 24/7 color imaging.
- 40 m illumination distance.
- Super Adapt.
- Built-in MIC.
- Quick-to-install eyeball saves installation time.
- 3.6 mm fixed lens (2.8 mm optional).
- CVI/CVBS/AHD/TVI switchable.
- IP67, 12 VDC.



Protection (IP67, Wide Voltage)

IP67: The camera passed a series of rigorous dust and immersion tests. Its enclosure is both dust-proof and waterproof, and can function normally while being immersed in 1 m deep water for up to 30 minutes.
Wide voltage: The camera has $\pm 30\%$ input voltage tolerance (for some power supplies) and a wide voltage range, making it suitable for a variety of outdoor scenarios.

4 Signals over 1 Coaxial Cable

HDCVI technology supports 4 signals (video, audio*, data and power) which are simultaneously transmitted over a coaxial cable. Dual-way data transmission allows the HDCVI camera to interact with the XVR to perform various actions such as sending control signals and triggering alarms. HDCVI technology also supports PoC, which makes the camera easy and quick to install.

* Audio input is available for select HDCVI camera models.

Technical Specification

Camera

Pixel	2 MP
Image Sensor	2 MP CMOS
Max. Resolution	1920 (H) × 1080 (V)
Scanning System	Progressive
Electronic Shutter Speed	PAL: 1/25 s–1/100000 s NTSC: 1/30 s–1/100000 s
Min. Illumination	0.005 lux@F1.6 (Color) 0 lux (Illuminator on)
S/N Ratio	>65 dB
Illumination Distance	40 m (131.23 ft)
Illuminator On/Off Control	Auto/Manual
Illuminator Number	2 (Warm light)
Pan/Tilt/Rotation Range	Pan: 0°–360° Tilt: 0°–78° Rotation: 0°–360°

Lens

Lens Type	Fixed-focal				
Lens Mount	M12				
Focal Length	2.8 mm; 3.6 mm				
Max. Aperture	F1.6				
Field of View	2.8 mm: H: 108°; V: 58°; D: 127° 3.6 mm: H: 84°; V: 43°; D: 102°				
Iris Control	Fixed				
Close Focus Distance	2.8 mm: 0.7 m (2.30 ft) 3.6 mm: 1.3 m (4.27 ft)				
DORI Distance	Lens	Detect	Observe	Recognize	Identify
	2.8 mm	42.2 m (138.45 ft)	16.9 m (55.45 ft)	8.4 m (27.56 ft)	4.2 m (13.78 ft)
	3.6 mm	59.0 m (193.57 ft)	23.6 m (77.43 ft)	11.8 m (38.71 ft)	5.9 m (19.36 ft)

Video

Video Frame Rate	CVI: PAL: 1080p@25 fps; NTSC: 1080p@30 fps AHD: PAL: 1080p@25 fps; NTSC: 1080p@30 fps TVI: PAL: 1080p@25 fps; NTSC: 1080p@30 fps CVBS: PAL: 960H; NTSC: 960H
Resolution	1080P (1920 × 1080); 960H (960 × 576/960 × 480)
Day/Night	Color
BLC	BLC; HLC; DWDR;
WDR	DWDR
White Balance	Auto;Area white balance
Gain Control	Auto
Noise Reduction	3D NR
Illumination Mode	Smart Light
Mirror	Yes

Privacy Masking	Off/On (8 areas, rectangle)
-----------------	-----------------------------

Certification

Certifications	CE-LVD: EN 62368-1; CE-EMC: EN 55032; EN 55035 FCC: 47 CFR FCC Part 15, Subpart B
----------------	---

Port

Video Output	Video output choices of CVI/TVI/AHD/CVBS by one BNC port
Audio Input	One channel built-in MIC

Power

Power Supply	12 VDC ± 30%
Power Consumption	Max 5.2 W (12 V DC, LED on)

Environment

Operating Temperature	–40 °C to +60 °C (–40 °F to +140 °F)
Operating Humidity	<95% (RH), non-condensing
Storage Temperature	–40 °C to +60 °C (–40 °F to +140 °F)
Protection	IP67

Structure

Casing Material	Metal
Product Dimensions	93.6mm×106.0(Φ3.69"×4.17")
Packaging Dimensions	147 mm × 138 mm × 135 mm (5.79" × 5.43" × 5.31")
Net Weight	0.48 kg (1.06 lb)
Gross Weight	0.63 kg (1.39 lb)
Installation	Wall mount; ceiling mount; vertical pole mount

Ordering Information		
Type	Part Number	Description
2MP Camera	EZ-HAC-T4A29-F2	2MP Full-color HDCVI Eyeball Camera
Accessories (Optional)	PFA130-E	Water-proof Junction Box
	PFB204W	Wall Mount Bracket
	PFA106	Adapter Plate of Mini Dome & Eyeball Camera
	PFB220C	Ceiling Mount Bracket
	PFA152-E	Pole Mount Bracket
	PFM800-E	1 Channel Passive HDCVI Balun
	PFM321D	12V 1A Power Adapter
	PFM904	Integrated Mount Tester

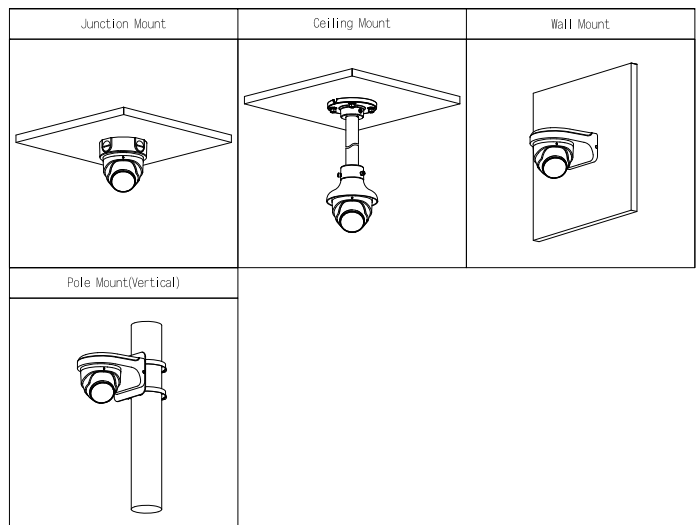

Accessories

Optional:



PFA130-E
Water-proof
Junction Box



PFB204W
Wall Mount Bracket



PFA106
Adapter Plate of Mini Dome
& Eyeball Camera



PFB220C
Ceiling Mount
Bracket



PFA152-E
Pole Mount
Bracket



PFM800-E
1 Channel Passive
HDCVI Balun



PFM321D
12V 1A Power
Adapter



PFM904
Integrated Mount
Tester

Dimensions (mm[inch])

